

WIRING OVATION™ ATS TO A CUMMINS/ONAN® STATIONARY GENERATOR



1-888-GEN-TRAN

This Diagram Covers:

SERIES	MODEL	FUEL	SIZE	ENGINE
RS20000	20GGMA-6110	NG	20kW	GM 4
	20GGMA-6111	LPG	20kW	GM 4
RS30000	30GGMC-6112	NG	29kW	GM 4
	30GGMC-6113	LPG	30kW	GM 4

Additional Parts Required:

1. GenTran PN: ATSRK 1
2. 18-4 300V control wire varies
3. GenTran PN: 2602A-12 1

Notes:
 • All control wire should be minimum 18AWG, 300 V rated

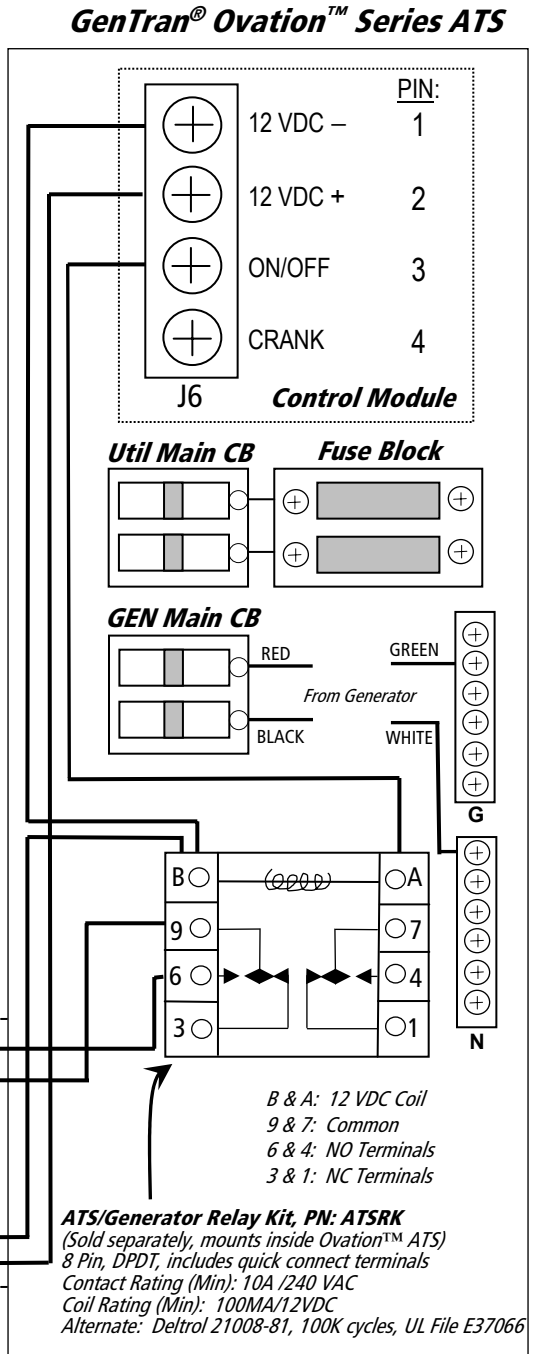
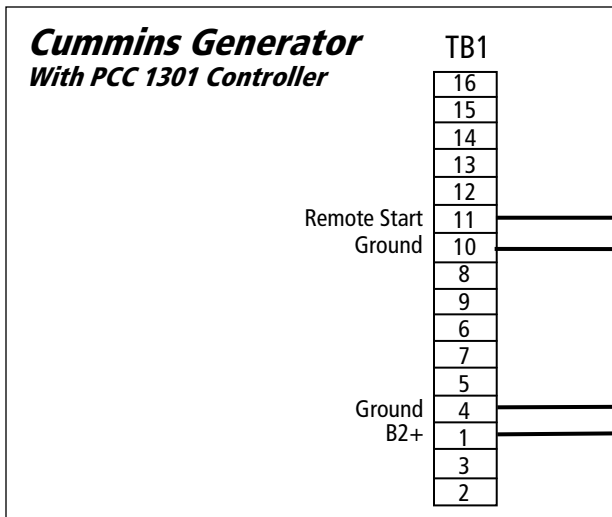

NOTE: The Ovation™ Series ATS does NOT include an integrated battery charger. Install 15A/120VAC receptacle and battery charger in generator (GenTran PN: 2602A-12).